



CML Semiconductor Products

PRODUCT INFORMATION

FX019 Digitally Controlled Quad Amplifier Array

Publication D/019/4 December 1995

Features

- 4 Digitally Controlled Amplifiers
- 15 Gain/Attenuation Steps
- 3 Amplifiers, with a $\pm 3\text{dB}$ Range in 0.43dB Steps
- 1 'Volume' Amplifier, with a $\pm 14\text{dB}$ Range in 2dB Steps
- 8-Bit Serial Data Control
- Output Mute Function
- Audio and Data Gain Control Applications
- Telecoms, Radio and Industrial Applications



Island Labs

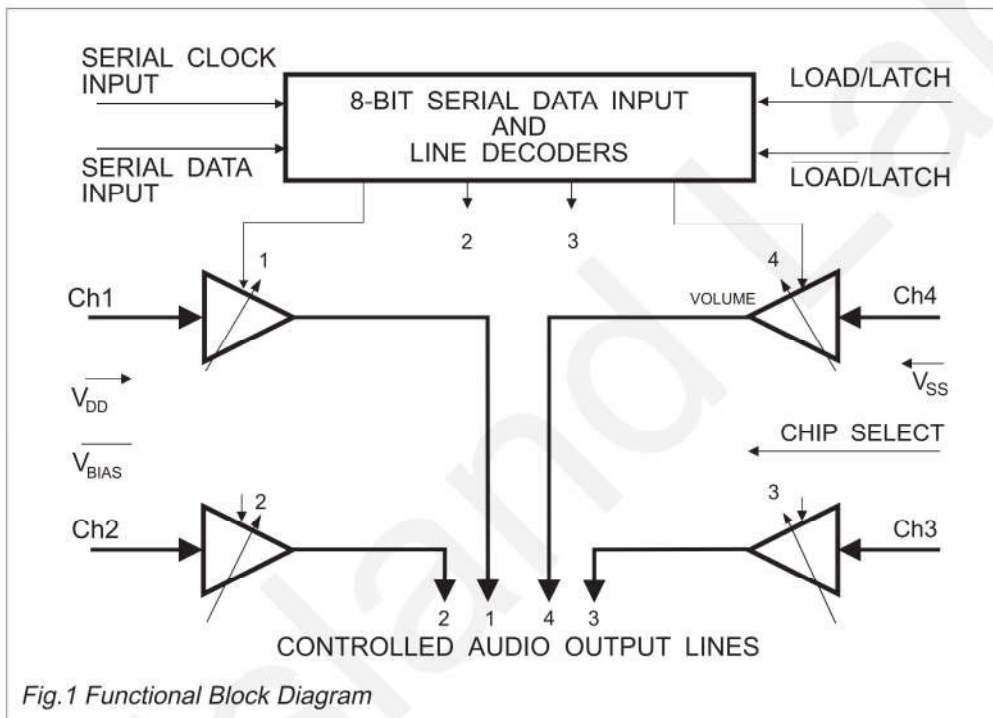

FX019

Brief Description

The FX019 Digitally Adjustable Amplifier Array is available to replace trimmer potentiometers and volume controls in Cellular, PMR, Telephony and Communications applications where d.c., voice or data signals need adjustment.

The FX019 is a single-chip LSI consisting of four digitally controlled amplifier stages, each with 15 distinct gain/attenuation steps. Control of each individual amplifier is by an 8-bit serial data stream. Three of the amplifier stages offer a $\pm 3\text{dB}$ range in steps of 0.43dB, whilst the remaining amplifier offers a $\pm 14\text{dB}$ range in steps of 2dB, and is suggested for volume control applications. Each amplifier includes a 16th 'Off' state which when applied, mutes the output audio from that channel. This array uses a Chip Select input to select one of two FX019s in a system.

This product replaces the need for manual trimming of audible signals by using the host microprocessor to digitally control the set-up of all audio levels during development, production/calibration and operation.

Applications include:

(i) Control, adjustment and set-up of communications equipment by an Intelligent ATE without manual intervention – eg. Deviation, Microphone and L/S Levels, Rx Audio Level etc.

(ii) Automatic Dynamic Compensation of drift caused by variations in temperature, linearity, etc.

(iii) Fully automated servicing and re-alignment.

The FX019 is a low-power, single 5-volt CMOS device available in plastic DIL and Small Outline (S.O.I.C.) SMD package versions.

Application Notes

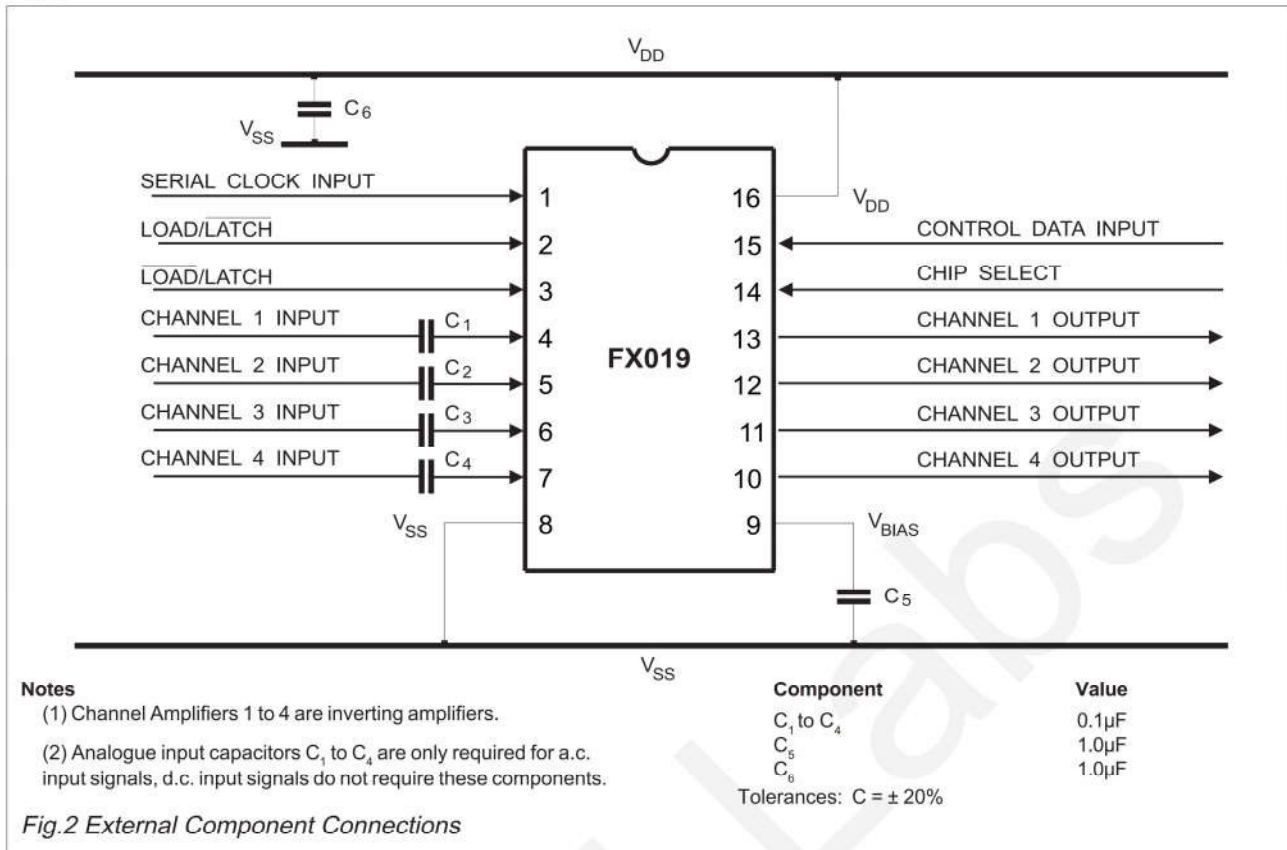

Application Recommendations

To avoid excess noise and instability in the final installation it is recommended that the following points be noted.

- (a) A noisy or badly regulated power supply can cause instability and/or variance of selected gains.
- (b) Care should be taken on the design and layout of the printed circuit board.
- (c) All external components (Figure 2) should be kept close to the FX019 package.
- (d) Inputs and outputs should be screened wherever possible.
- (e) Tracks should be kept short.
- (f) Analogue tracks should not run parallel to digital tracks.
- (g) A "Ground Plane" connected to V_{SS} will assist in eliminating external pick-up on the channel input and output pins.
- (h) Do not run high-level output tracks close to low-level input tracks.
- (i) Input signal amplitudes should be applied with due regard to Figure 3.

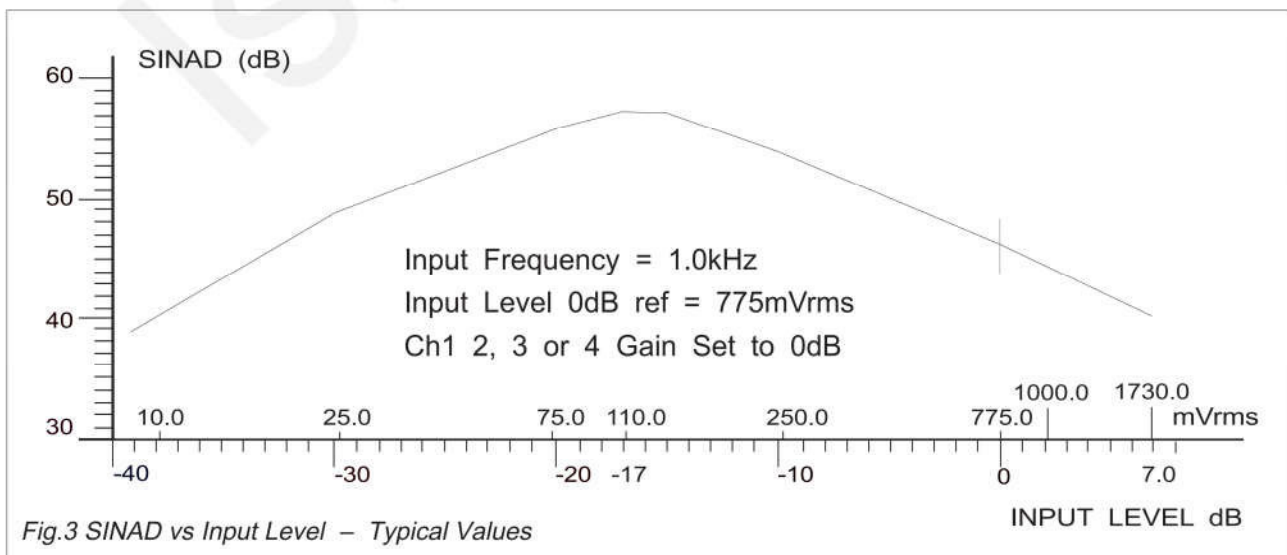

Control Data and Timing

The gain of each amplifier block (Channel 1 to Channel 4) in the FX019 is set by a separate 8-bit data word (bit 7 to bit 0). This 8-bit word, consisting of 4 Address bits (bit 7 to bit 4) and 4 Gain Control bits (bit 3 to bit 0), is loaded to the Control Data Input in serial format using the external data clock.

Data is loaded to the FX019 on the rising edge of the Serial Clock. Loaded data is executed on the falling (rising) edge of the Load/Latch (Load/Latch) pulse. Table 1 shows the format of each 4-bit Address word, Table 2 shows the format of each Gain Control word with Figure 4 describing the data loading operation and timing.

Bit 7 MSB	Bit 6	Bit 5	Bit 4 LSB	Channel Selected	Chip Select	Chip Number
1	0	0	0	1	0	Chip 1
1	0	0	1	2	0	
1	0	1	0	3	0	
1	0	1	1	4	0	
1	1	0	0	1	1	Chip 2
1	1	0	1	2	1	
1	1	1	0	3	1	
1	1	1	1	4	1	

Bit 3 MSB	Bit 2	Bit 1	Bit 0 LSB	Stage 1, 2, 3 (0.43dB)	Stage 4 (2.0dB)
0	0	0	0	OFF	OFF
0	0	0	1	-3.0	-14.0dB
0	0	1	0	-2.571	-12.0
0	0	1	1	-2.143	-10.0
0	1	0	0	-1.714	-8.0
0	1	0	1	-1.286	-6.0
0	1	1	0	-0.857	-4.0
0	1	1	1	-0.428	-2.0
1	0	0	0	0	0
1	0	0	1	0.428	2.0
1	0	1	0	0.857	4.0
1	0	1	1	1.286	6.0
1	1	0	0	1.714	8.0
1	1	0	1	2.143	10.0
1	1	1	0	2.571	12.0
1	1	1	1	3.0	14.0

Data Loading

The 8-bit data word is loaded *bit 7 first and bit 0 last*. Bit 7 must be a logic "1" to address the chip. If bit 7 in the word is a logic "0" that 8-bit word will not be executed. The Chip Select input permits the use of two devices in a system; To facilitate this, Bit 6 can be either a logic "0" or "1." Figure 4 (below) shows the timing information required to load and operate this device.

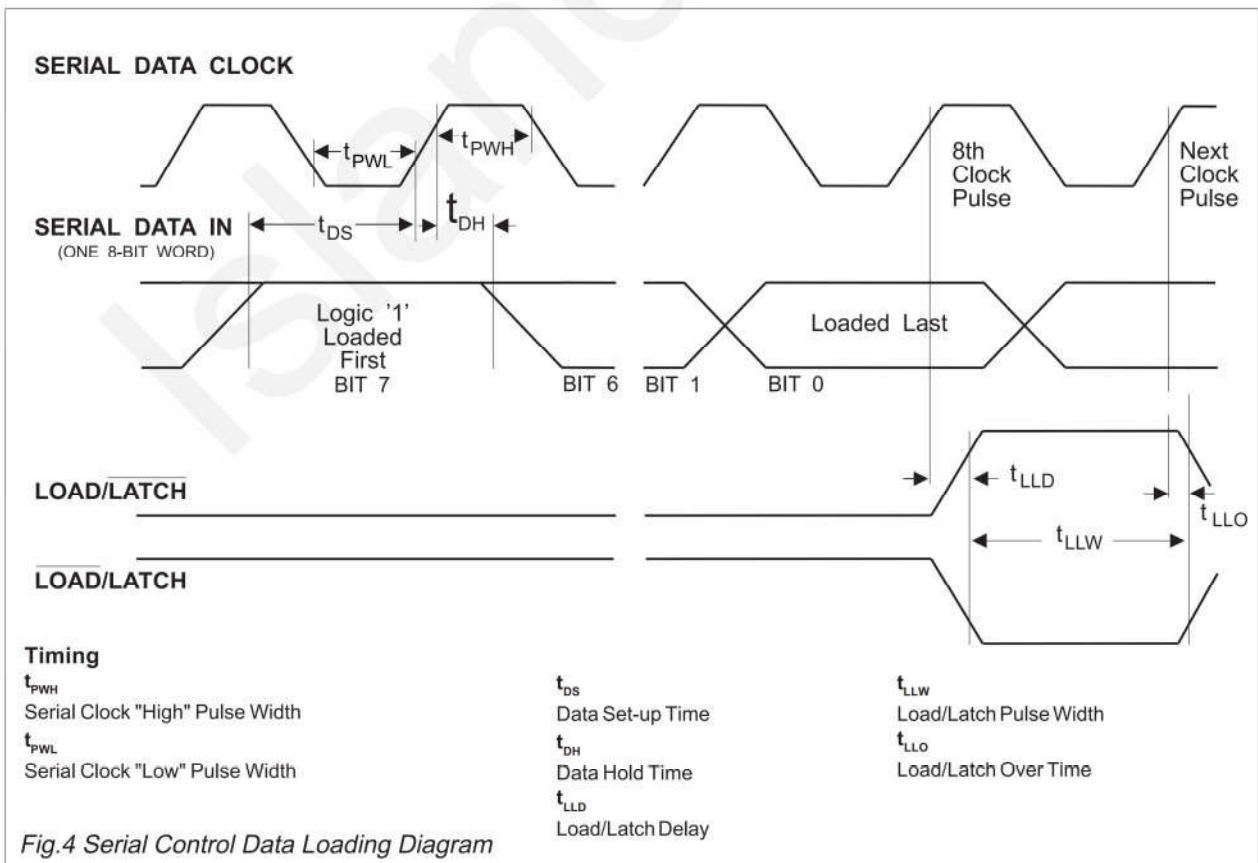

Specification

Absolute Maximum Ratings

Exceeding the maximum rating can result in device damage. Operation of the device outside the operating limits is not implied.

Supply voltage	-0.3 to 7.0V
Input voltage at any pin (ref $V_{SS} = 0V$)	-0.3 to ($V_{DD} + 0.3V$)
Sink/source current (supply pins)	+/- 30mA
(other pins)	+/- 20mA
Total device dissipation @ $T_{AMB} = 25^{\circ}C$	800mW Max.
Derating	10mW/ $^{\circ}C$
Operating temperature range: FX019DW/P	-40 $^{\circ}C$ to +85 $^{\circ}C$ (plastic)
Storage temperature range: FX019DW/P	-40 $^{\circ}C$ to +85 $^{\circ}C$ (plastic)

Operating Limits

All device characteristics are measured under the following conditions unless otherwise specified:

$V_{DD} = 5.0V$, $T_{AMB} = 25^{\circ}C$. Audio Level 0dB ref: = 775mVrms. Amplifier Gain Set = 0dB.

Characteristics	See Note	Min.	Typ.	Max.	Unit
Static Values					
Supply Voltage (V_{DD})		4.5	5.0	5.5	V
Supply Current		-	1.5	-	mA
Dynamic Values					
Control Functions					
Input Logic '1'		3.5	-	-	V
Input Logic '0'		-	-	1.5	V
Digital Input Impedances		0.5	1.0	-	M Ω
Amplifier Stages (General)					
Bandwidth (-3dB)		20.0	-	-	kHz
Output Impedance		-	1.0	-	k Ω
Total Harmonic Distortion	1	-	0.35	0.5	%
Output Noise Level (per stage)	2	-	180.0	400.0	μ Vrms
Onset of Clipping	3	-	1.73	-	Vrms
Gain Variation	4	-	-	0.1	dB
Interstage Isolation		-	60.0	-	dB
"Trimmer" Stages (Ch1 – Ch3)					
Gain		-3.0	-	+3.0	dB
Gain per Step (15 in No.)		-	0.43	-	dB
Step Error	5	-	-	± 0.2	dB
Input Impedance		100.0	-	-	k Ω
"Volume" Stage (Ch4)					
Gain		-14.0	-	+14.0	dB
Gain per Step (15 in No.)		-	2.0	-	dB
Step Error	5	-	-	± 0.4	dB
Input Impedance		50.0	-	-	k Ω
Timing (Figure 4)					
Serial Clock "High" Pulse Width (t_{PWH})		250	-	-	ns
Serial Clock "Low" Pulse Width (t_{PWL})		250	-	-	ns
Data Set-up Time (t_{DS})		150	-	-	ns
Data Hold Time (t_{DH})		50.0	-	-	ns
Load/Latch Pulse Width (t_{LLW})		150	-	-	ns
Load/Latch Delay (t_{LLD})		200	-	-	ns
Load/Latch Over (t_{LLO})		-	-	50.0	ns
Serial Data Clock Frequency		-	-	2.0	MHz

Notes

- Gain Set 0dB, Input Level 1kHz -3.0dB (549mVrms).
- With an a.c short-circuit input, measured in a 30kHz bandwidth.
- See Figure 3.
- Over the temperature and supply voltage range.
- With reference to a 1.0kHz signal.

Package Outlines

The FX019 is available in the package styles outlined below. Mechanical package diagrams and specifications are detailed in Section 10 of this document.

Pin 1 identification marking is shown on the relevant diagram and pins on all package styles number anti-clockwise when viewed from the top.

Handling Precautions

The FX019 is a CMOS LSI circuit which includes input protection. However precautions should be taken to prevent static discharges which may cause damage.

FX019DW 16-pin plastic S.O.I.C. (D4)

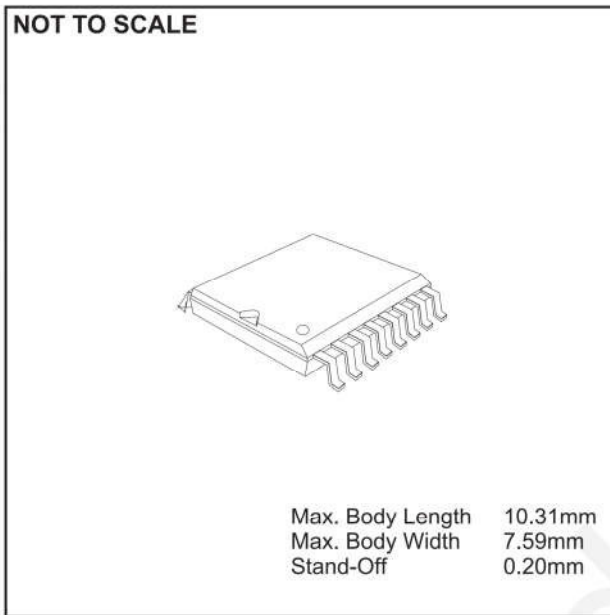

FX019P 16-pin plastic DIL (P3)

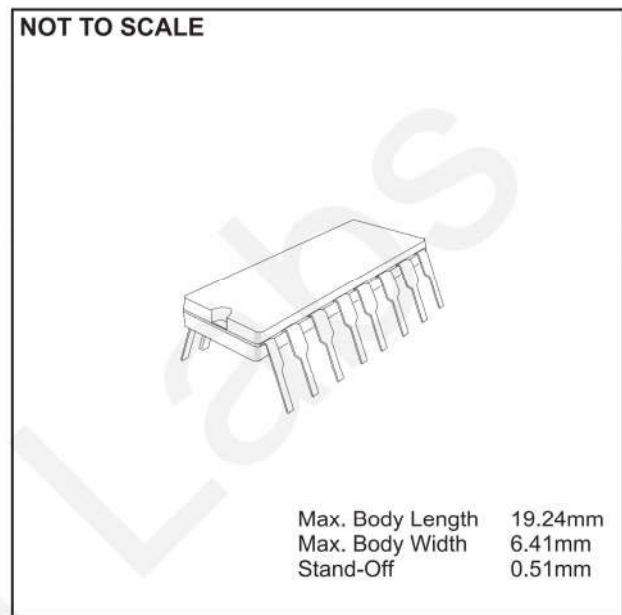

Ordering Information

FX019DW 16-pin plastic S.O.I.C. (D4)

FX019P 16-pin plastic DIL (P3)

CML does not assume any responsibility for the use of any circuitry described. No circuit patent licences are implied and CML reserves the right at any time without notice to change the said circuitry.



CML Microcircuits

COMMUNICATION SEMICONDUCTORS

CML Product Data

In the process of creating a more global image, the three standard product semiconductor companies of CML Microsystems Plc (*Consumer Microcircuits Limited (UK)*, *MX-COM, Inc (USA)* and *CML Microcircuits (Singapore) Pte Ltd*) have undergone name changes and, whilst maintaining their separate new names (*CML Microcircuits (UK) Ltd*, *CML Microcircuits (USA) Inc* and *CML Microcircuits (Singapore) Pte Ltd*), now operate under the single title **CML Microcircuits**.

These companies are all 100% owned operating companies of the CML Microsystems Plc Group and these changes are purely changes of name and do not change any underlying legal entities and hence will have no effect on any agreements or contacts currently in force.

CML Microcircuits Product Prefix Codes

Until the latter part of 1996, the differentiator between products manufactured and sold from MXCOM, Inc. and Consumer Microcircuits Limited were denoted by the prefixes MX and FX respectively. These products use the same silicon etc. and today still carry the same prefixes. In the latter part of 1996, both companies adopted the common prefix: CMX.

This notification is relevant product information to which it is attached.

Company contact information is as below:



**CML Microcircuits
(UK) Ltd**

COMMUNICATION SEMICONDUCTORS

Oval Park, Langford, Maldon,
Essex, CM9 6WG, England
Tel: +44 (0)1621 875500
Fax: +44 (0)1621 875600
uk.sales@cmlmicro.com
www.cmlmicro.com



**CML Microcircuits
(USA) Inc.**

COMMUNICATION SEMICONDUCTORS

4800 Bethania Station Road,
Winston-Salem, NC 27105, USA
Tel: +1 336 744 5050,
0800 638 5577
Fax: +1 336 744 5054
us.sales@cmlmicro.com
www.cmlmicro.com



**CML Microcircuits
(Singapore) Pte Ltd**

COMMUNICATION SEMICONDUCTORS

No 2 Kallang Pudding Road, 09-05/
06 Mactech Industrial Building,
Singapore 349307
Tel: +65 7450426
Fax: +65 7452917
sg.sales@cmlmicro.com
www.cmlmicro.com